

The MD2 Motor Driver

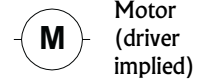

The MD2 Motor Driver is a variation of the long-proven 74xx245 Motor Driver, which is a strict buffer. This version uses the 74AC240 to keep chip-type count down. The major difference is that this version has inverting outputs, so a low signal in means a high signal out.

Necessary Parts:

- 1 x 74AC245
- 1 x 22 μ F Electrolytic Pwr Filtration Capacitor (C3)

Other Parts:

- 1 x 47k Ω Optional enable Resistor (Yel/Pur/Or) (R1)

The inputs are all located on the upper half of the module, and the outputs are all on the lower half.

To drive a motor bi-directionally (clockwise & counter-clockwise), solder inputs 1-4 together (we'll call this input "A"), and inputs 5-8 together (input "B"). Solder jumpers work well for this application. Then solder outputs 1-4 together (output "A"), and outputs 5-8 together (output "B"). Put your two signal inputs across inputs A & B, and you motor across outputs A & B. As long as your input signals are different polarities, you'll get motor rotation.

Ganging the inputs/outputs of the MD2 increases the drive current. If you have efficient motors, you may be able to drive two separate motors - just gang the inputs into pairs(2) instead of quads (4).

If you require unidirectional motor rotation (spins only 1 way), put your motor leads from the output to either Vcc or Ground.



Top

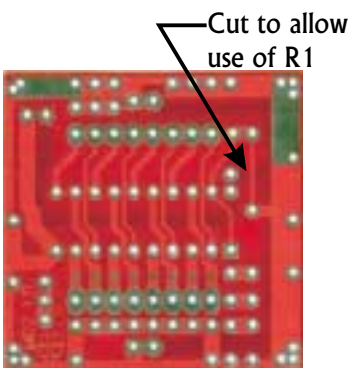

Bottom

- Edge Rail of PCB is Ground (-).
- Top/Bottom Center pad is Vcc (+).
- Inputs located on upper half of module.
- Outputs located on lower half of module.
- Group Inputs/Outputs together to increase drive current.
- Motor connections from outputs to either Vcc or Ground give unidirectional rotation.
- If motor rotation is incorrect for your application, reverse either motor leads or input leads.
- Use R1 enable resistor to be able to over-ride "default on" by applying "high" signal to point E1 (cut R1 jumper trace on bottom of module first). This can be used for Pulse-Width-Modulated (PWM, meaning many quick pulses) speed control of the motor driver.

